

3" ELECTRIC DIAPHRAGM PUMP TECHNICAL DATA SHEET



SERIES:
HEAVY DUTY ELECTRIC DIAPHRAGM PUMP

Engineered for the World's Most Challenging Fluid Transfer Applications

SPECIFICATIONS

SUCTION / DISCHARGE PORT SIZE - MM (IN)

- 76 mm (3") / Aluminum - ANSI 150# Raised Face Flanges / Stainless Steel - NPT (internal)

MAXIMUM FLOW RATE LPM (GPM)

- 510 LPM (135 GPM)

SOLIDS HANDLING - MM (IN)

- Up to 7 MM (.28")

MAX OPERATING PRESSURE - BAR (PSI)

- 6 BAR (87 PSI)

MAXIMUM SUCTION LIFT - M (FT)

- 8M+ Wet / 4.2M Dry (26'+ Wet / 14' Dry)*

*Applicable to Santoprene and PTFE Diaphragms only

HEADS UP TO - M (FT)

- 60M (196')

DISPLACEMENT PER CYCLE - L (GAL)

- 2.88L (0.76 GAL)

MOTOR & GEAR BOX - KW (HP)

- 5.5 KW (7.5HP)

SOUND LEVEL

- <80 dB

DISCHARGE MANIFOLD

DAMPENER PORT - MM (IN)

- 51 MM (2")

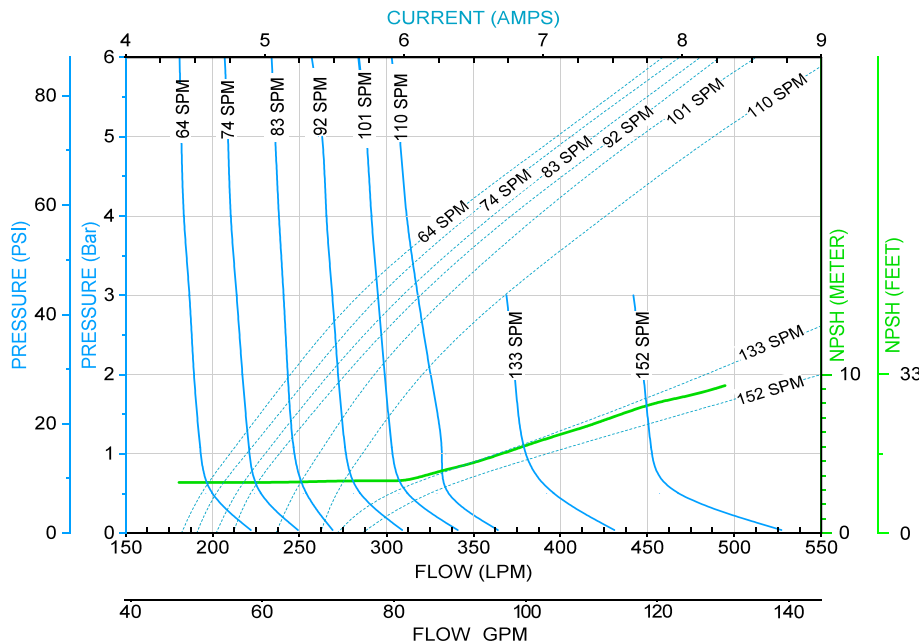

Notes:

1. Use 7.5 HP / 5.5 KW motor for above 7 AMPS
2. For SPM 152 and 133, contact IDEX Team
3. The performance curve is based on following: Santoprene elastomer fitted pump, flooded suction, water at ambient conditions 25°C (77°F), with Cognito Dampener
4. The performance result may deviate in excess of 5% based on elastomer

DIMENSIONS

INLINE ARRANGEMENT

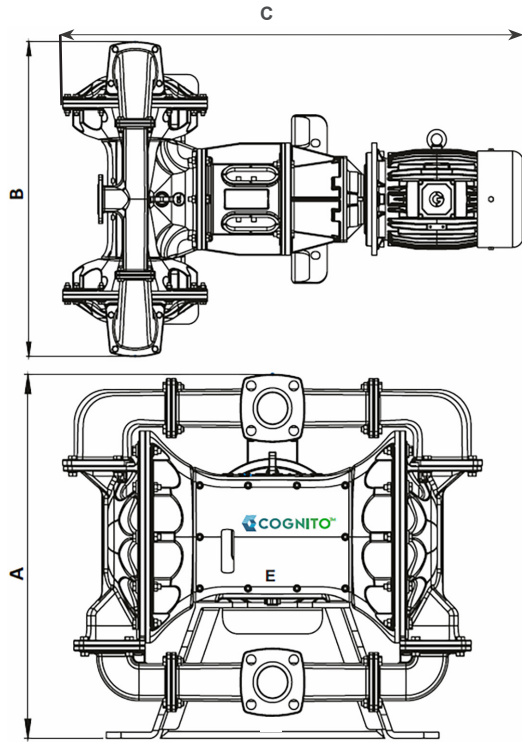

Dimensions & Weight - Inline

DIMENSION & WEIGHT - INLINE*		76 MM (3")
ALUMINUM		
Height w/o Dampener: MM (IN)	A	740mm (29.13")
Width: MM (IN)	B	850mm (33.46")
Ref Length: MM (IN)	C	1295mm (50.98")
Approx Weight: KG (LBS) Bare Pump	W	220 KG (485 LBS)
Approx Weight: KG (LBS) Pump, Motor, Gear Box, Dampener	W	365 KG (804 LBS)
STAINLESS STEEL		
Height: MM (IN)	A	707mm (27.83")
Width: MM (IN)	B	833mm (32.76")
Ref Length: MM (IN)	C	1295mm (50.98")
Approx Weight: KG (LBS) Bare Pump	W	260 KG (573 LBS)
Approx Weight: KG (LBS) Pump, Motor, Gear Box, Dampener	W	415 KG (914 LBS)

*FINAL PUMP ASSEMBLY WEIGHTS AND DIMENSIONS DEPENDENT ON GEAR BOX AND MOTOR MANUFACTURER

VERTICAL ARRANGEMENT

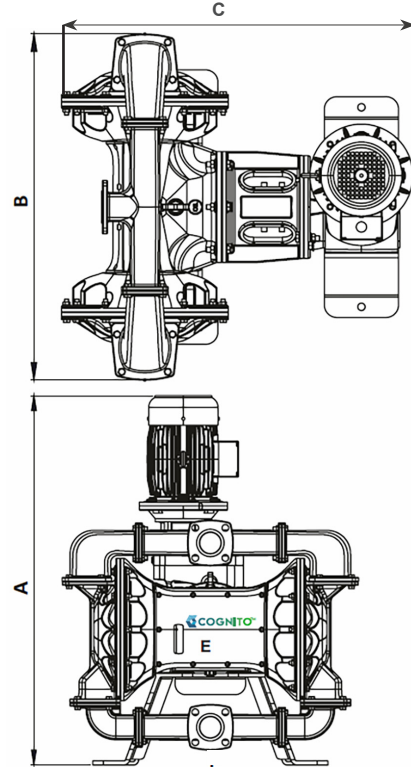

Dimensions & Weight - Vertical

DIMENSION & WEIGHT - VERTICAL *		76 MM (3")
ALUMINUM		
Ref Height: MM (IN)	A	1220mm (48.03")
Width: MM (IN)	B	850mm (33.46")
Ref Length: MM (IN)	C	925mm (36.42")
Approx Weight: KG (LBS) Bare Pump	W	220 KG (485 LBS)
Approx Weight: KG (LBS) Pump, Motor, Gear Box, Dampener	W	365 KG (804 LBS)
STAINLESS STEEL		
Height: MM (IN)	A	1220mm (48.03")
Width: MM (IN)	B	833mm (32.76")
Ref Length: MM (IN)	C	925mm (36.42")
Approx Weight: KG (LBS) Bare Pump	W	260 KG (573 LBS)
Approx Weight: KG (LBS) Pump, Motor, Gear Box, Dampener	W	415 KG (914 LBS)



IDEX INDIA PVT LTD
Survey No. 256, Near Bombardier Circle,
GIDC Manjusar, Savli, Dist. Vadodara
391770, State Gujarat, India



Warren Rupp, Inc.
800 North Main Street
Mansfield, Ohio 44902 USA



www.cognitopump.com/contact